

Midland ERK and C Kit
Mounting to the NGRTC
“Enhanced Fittings”
Package

Capping NGRTC “Enhanced Fittings”

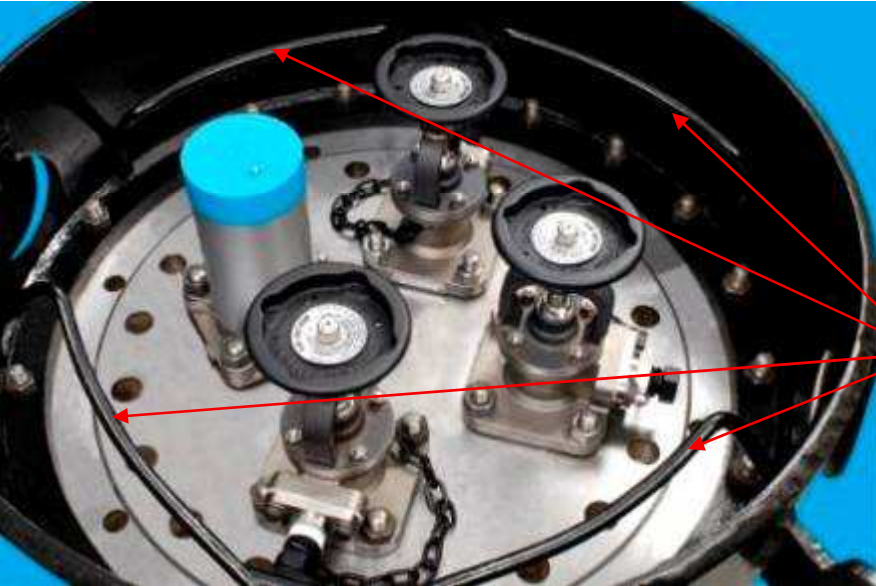

- The NGRTC fittings package has a new protective housing for Chlorine applications
 - Lower profile
 - Wider layout, equal to an LPG style or 20” housing
- Four bars are mounted inside the housing to accommodate the “C” kit

Mounting Options for Capping Kits

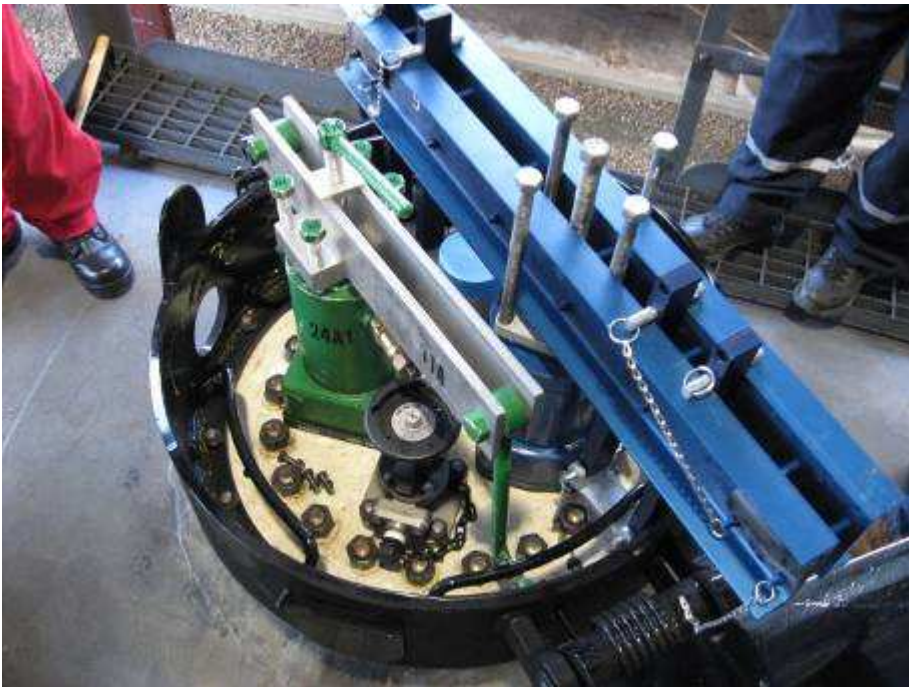

- Note that two kits were able to be applied simultaneously using the bars inside the dome
 - The Midland ERK could also use the port holes to connect just as is currently done today.
 - If using the port holes, only one kit could be applied at a time
- The angle valves require the same capping can as the PRV
 - Midland capping can #4 is the correct can to use

Mounting Options for Capping Kits

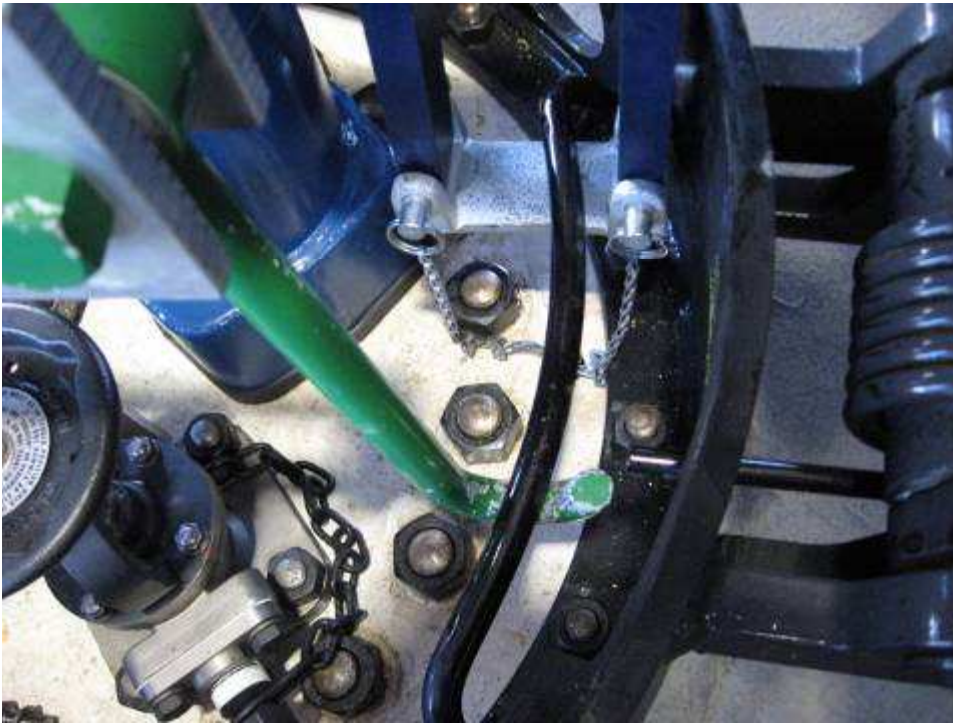

- With the four interior bars, the “C” kit hooks and the ERK tie bars have room to “find” the right spot to create a good connection for sealing over the capping can
- The bar does not interfere with the valves or the side of the protective housing

Mounting Options for Capping Kits



- The Angle Valve still requires the handwheel be removed before capping
- The flange face plate also needs to be removed before capping
 - A recommended practice to aid in removal is to apply a 1” pipe (as shown in this picture) to help pull out the flange plate
 - The 1” pipe is not included in either the ERK or “C” kits and would need to be added
- The chain and plug do not need to be removed, wrap these around the valve to keep out of the way of the can

Mounting Options for Capping Kits

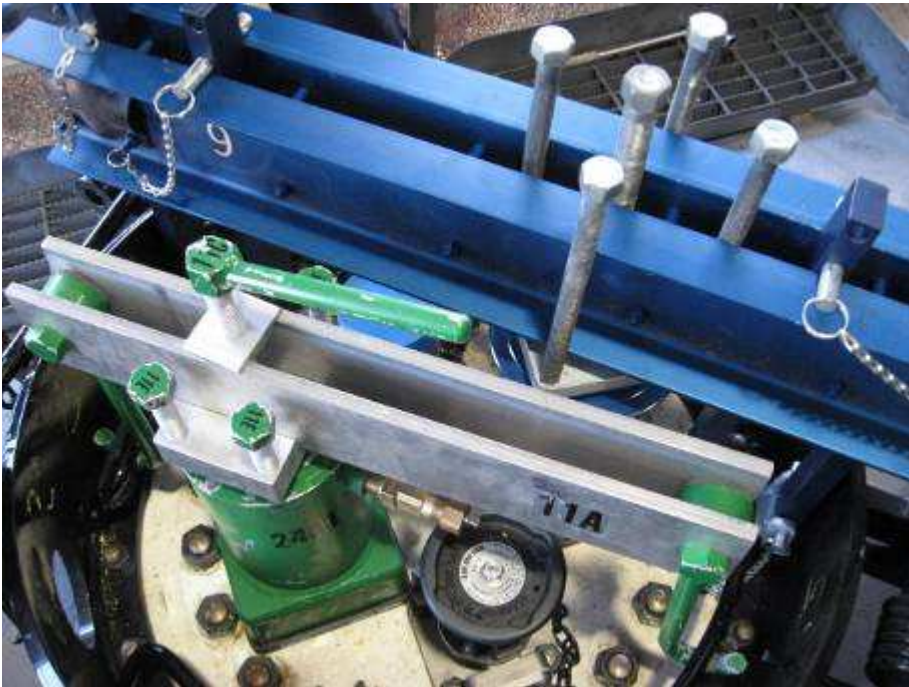

- The bars are being used for the first 25 railcars in the service trial. Other options could be considered in the future
 - Any new designs need to consider the “reach” of the C kit hooks
- The C kit will work in the port holes through the following:
 - Unbolt one of the hooks
 - Mount both hooks into port holes
 - Re-attach the hook and tighten normally

Side View of the NGRTC Assembly

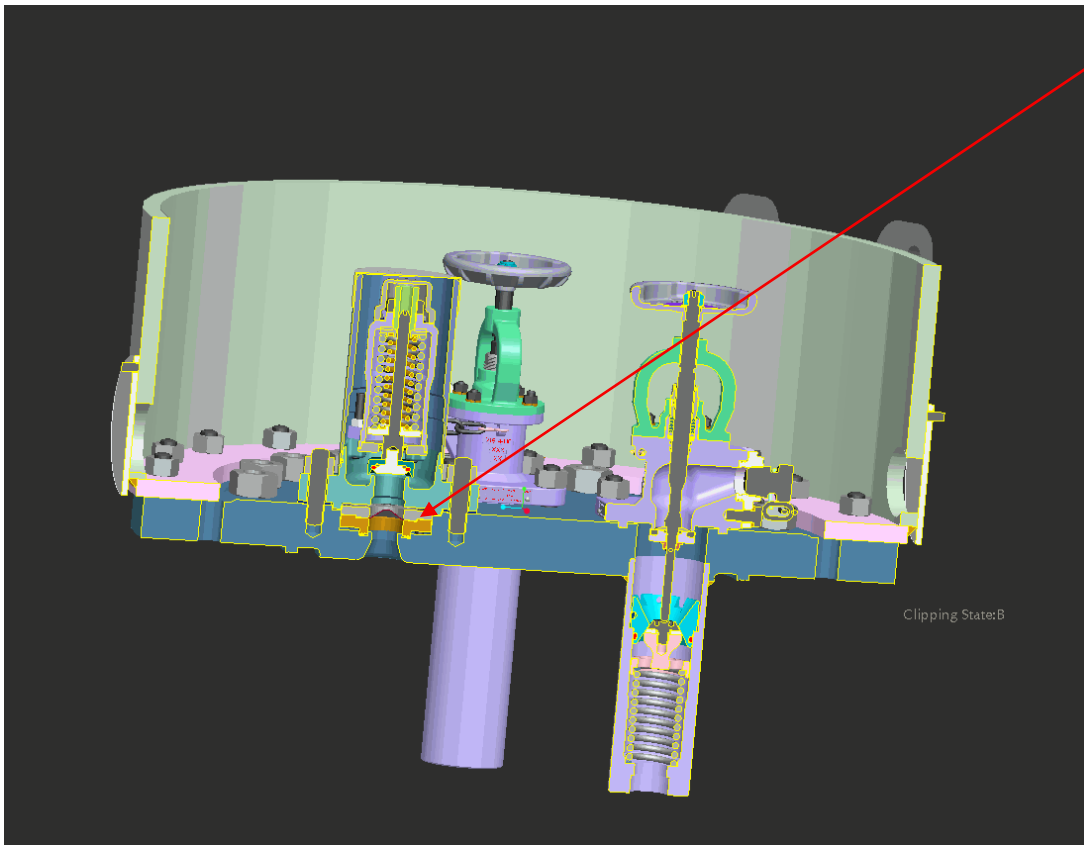

- Note the PRV rupture disc is mounted in the pressure plate
- The check valve is mechanically operated by the angle valve
 - The check valve spring maintains a positive seal on the valve until pushed open by the angle valve stem
- Primary seals are below the pressure plate surface

NGRTC Valve Operation

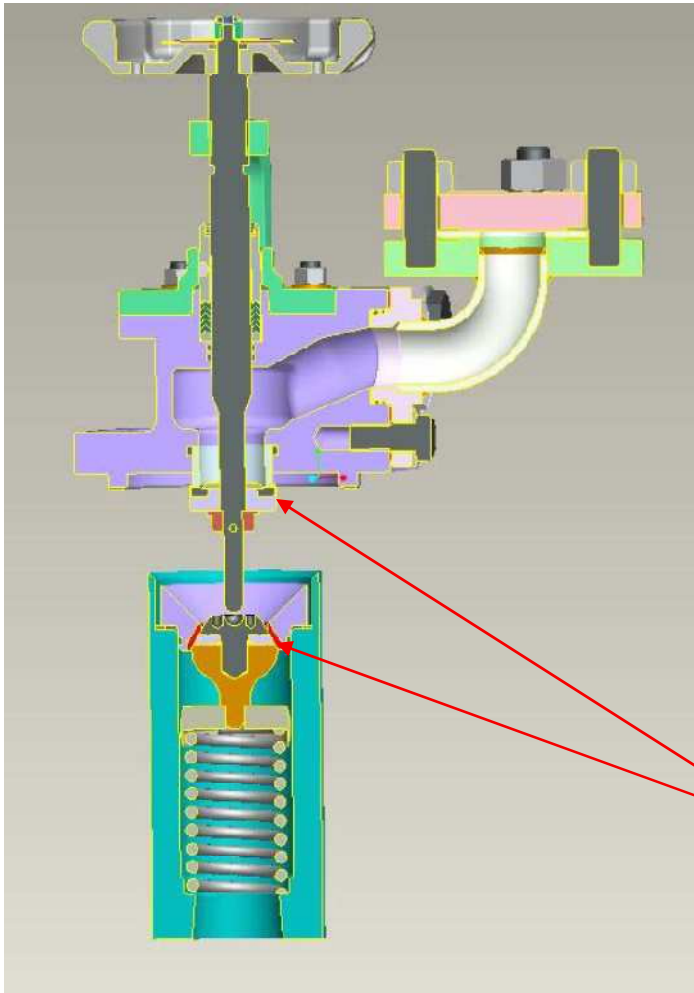

- The A-718 angle valve operates the same as a current angle valve
 - Left turn (counterclockwise to open) and right turn (clockwise to close)
- The stem is a descending stem so:
 - The handwheel will be at its **highest** point in the closed position
 - The handwheel will be at its **lowest** point in the open position
- The stem interacts with the check valve to push it open
- The check valve is the primary seal
- Both the check valve and angle valve have soft seats allowing better sealing